



INMOTION Controls Inc.

**INSTALLATION &
OPERATION
MANUAL**

INMOTION Control Series 322

July, 2003

INMOTION CONTROLS SERIES 322

TABLE OF CONTENTS

	Page
Safety Considerations	2
Part 1 Operator's Manual	
Chapter 1 Warranty	3
Chapter 2 Operating Precautions	4
Chapter 3 Standard Accessories	6
Chapter 4 Operation	7
Chapter 5 Inspection and Maintenance	14
Part 2 Technician's Manual	
Chapter 1 General Characteristics	15
Chapter 2 System Configuration	16
Chapter 3 Installation and Function Settings	19
Chapter 4 Troubleshooting	24

Safety Considerations

This product and related documentation must be reviewed for familiarization with safety markings and instructions before operation.

Safety Symbols The following symbols may be found on the remote control or throughout the remote control's documentation.



Refer to Manual

When the product is marked with this symbol refer to the instruction manual for additional information.



High Voltage

Indicates presence of hazardous voltage. Unsafe practice could result in severe personal injury.



Protective Earth Ground

Indicates protective earth ground terminal.



Warning

Denotes a hazard. Included text gives proper procedures. Failure to follow instructions could result in severe personal injury and/or property damage.



Caution

Denotes a hazard. Included text gives proper procedures. Failure to follow instructions could result in minor personal injury and/or property damage.

PART 1 OPERATOR'S MANUAL

Chapter 1 Warranty

1 - 1 Warranty

INMOTION Controls, Inc. guarantees that this equipment meets its published specifications at the time of shipment from the factory. This equipment will perform as described if installed properly. However, INMOTION Controls cannot guarantee that operation of Series 322 system is absolutely error-free, or without interruption.

1 - 2 Warranty Period

This equipment is warranted against defects in materials and workmanship for a period of one year from the date of shipment. During the warranty period, INMOTION Controls is responsible for necessary repairs as long as the product can be proved to be defective.

For warranty service or repair, this equipment must be returned to our factory. Customer is responsible for shipping charges to INMOTION Controls, while INMOTION Controls will pay return shipping charges.

1 - 3 Excluded Items



This warranty does not include consumable parts such as Joystick, batteries, fuses, buttons and relays. Also this warranty does not cover defects caused by improper installation, improper or insufficient maintenance, unauthorized modification, unavoidable natural essential, improper operation, ignorance of environmental specifications, improper software/interfaces.

1 - 4 Remarks

1. No other warranty is expressed or implied, except for the above mentioned.
2. The remedies provided herein are the buyers' sole and exclusive remedies. INMOTION Controls shall not be liable for any direct/indirect, special, incidental or consequential damages.

Chapter 2 Operating Precautions

2 - 1 Attention

1. Read this manual carefully before operating and installing Series 322.
2. Due to the complex nature of equipment, it is necessary to read the entire manual before installation.
-  3. Never dismantle equipment by any unauthorized personnel, or equipment may be damaged.
4. This manual is for reference only; please call your distributor if further assistance is required.
5. The equipment has been strictly tested for quality before delivery from our plant. However, it must not be used in extremely dangerous situations, or where damage may result.
6. After operating please shut off main power in Crane, the power to Receiver and remove Transmitter key.
7. Transmitter should be placed safely when not in use to avoid accidental pressing of buttons.
8. The Crane should be equipped with main power Relay, Limit Switch and other required safety devices.
-  9. The GND (ground) of Receiver must be connected with metal part of Crane, or electrical shock will occur.
10. Do not use this device during electrical storm or high electrical interference conditions.
11. Ensure Transmitter batteries are in good condition and power for Receiver is normal.
12. Installation and maintenance should be done only while the Crane's main power and Receiver's power are off, to prevent electrical shock.
13. Contents of the manual may be amended by the manufacturer without notice.
14. The manufacturer may introduce new functions to the equipment as necessary; therefore, the descriptions may change.
15. The patent and related documents for this equipment belong to INMOTION Controls, Inc. and are not allowed to be used by others without written permission.
16. Series 322 system is manufactured with many patents developed and owned by INMOTION Controls and its related enterprises.



2 - 2 Precautions

1. After operating Series 322, please press EMS mushroom to shut off main power in the Crane & Receiver and remove Transmitter key.
2. Stop operating when slow-response occurred due to insufficient Transmitter power, beyond the remote control range, or severe interference.
3. Remove the batteries when the equipment won't be used for a long period.
4. Operators must be in good health and have good judgement in regards to safety.
5. Remote control operator must have adequate training and related license to avoid danger.
6. Series 322 Transmitter is durable and weather-resistant, but care should be taken not to subject it to severe impact or pressure.
7. Series 322 is suitable for use in diverse industrial environment, and adequate operating and maintenance will extend system's life.
8. Check EMS mushroom and the other security functions of Series 322 system before daily operation.
9. Stop operating if operator's view is not clear.
10. Press EMS mushroom when malfunctions or abnormal conditions occur.
11. Operator must be familiar with the following Emergency Procedures before operating.



2 - 3 Emergency Procedures

In case of emergency, please follow the steps below and ask the distributor for service immediately.

1. Press EMS mushroom.
2. Turn the security key to "OFF" position.
3. Remove the battery box and key.
4. Shut off the main power of the Crane and discontinue the operation.
5. Contact the distributor to find out reasons.

Chapter 3 Standard Accessories

A standard and full set of Series 322 consists of:

(1) Transmitter, 1 unit



(2) Receiver, 1 unit



Chapter 4 Operation

4-1 Transmitter Configuration

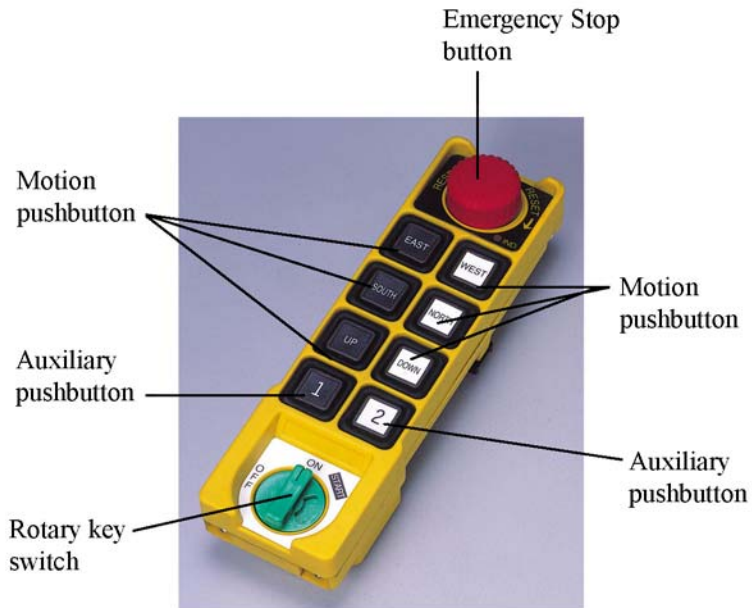

Figure 4-1 Transmitter Configuration

4-2 Receiver Configuration

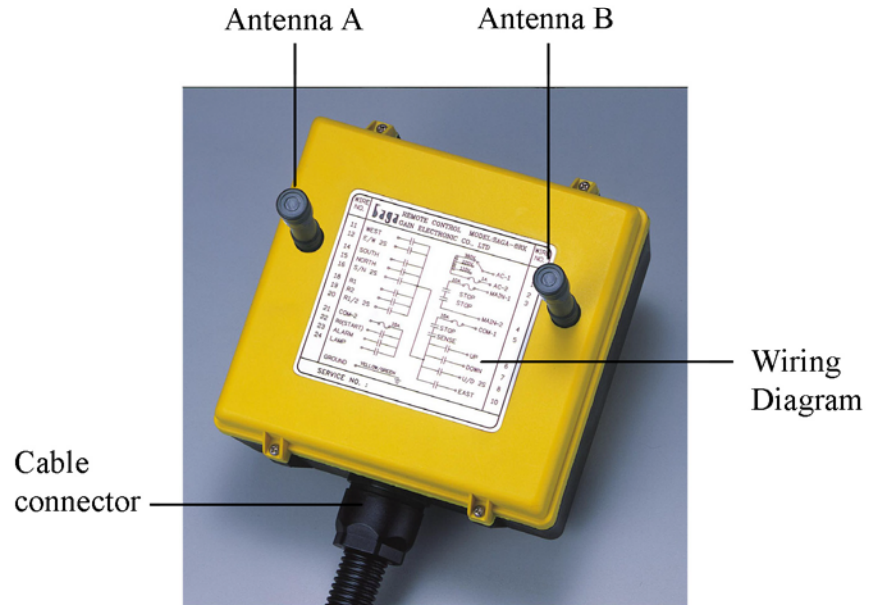



Figure 4-2 Receiver Configuration

4 – 3 General Operation

1. Install 4 AA batteries in the battery box. Make sure the “+” and “-” directions are correct.
2. Put batteries into battery compartment, then attach transmitter bottom cover with screws.
Note: Transmitter will sound two long sound to indicate the correct installation.
3. Insert security key in the “OFF” position.
4. Turn on the power according to the “Power-On Modes” (please refer to 4-4-1).
Note: LED indicator will flash with red color if proper procedures are not followed.
5. Operate transmitter by pressing each pushbutton.
6. After operation, perform the following procedures in sequence:
 - (1) Press EMS mushroom,
 - (2) turn rotary key switch counter-clockwise to the “OFF” position,
 - (3) remove key and keep it in a safe place,
 - (4) remove batteries if not used for a long period.**Note:** Transmitter has power indicating functions with LED display.
 - ← “Green color”: Sufficient power to operate transmitter. (In order to save power, one can program to turn off LED display when power is sufficient.)
 -  ↑ “Yellow color”: Power is depleting, warning sound occurs every 4 seconds (can be switched off and sound interval can be set by software). Operation must be stopped immediately (for example: down the goods to ground) to replace batteries.
 -  → “Red color”: Insufficient power. In addition to red LED, warning sound will continue and transmitter is no longer functional. Transmitter will send out an emergency stop signal to the receiver due to insufficient power. Operator should avoid this situation in order to maintain the safety of operation.

4 – 4 Special Functions Operation

4-4-1 Power-On operation

Power-on means that the Main-Relay on receiver will energize as soon as receiving the control data from transmitter and then receiver keep in condition of standby for continuous control. There are 4 different ways of “Power-On mode”.

A. Any pushbutton Power-On Mode

1. Rotate “EMS” mushroom clockwise 45° and pull out.
2. Turn rotary key switch clockwise to “ON” position.
3. Press any pushbutton on the transmitter. This will turn on the power as well as execute the function of pushbutton.

B. “Start” pushbutton Power-On Mode

1. Rotate “EMS” mushroom clockwise 45° and pull out.
2. Turn rotary key switch clockwise to “ON” position.
3. Continue to turn rotary key switch to “START” position to turn on power. (after release rotary key switch, it will automatically back to “ON” position.)

Note: When setting is on “Any pushbutton power-on” or “Start pushbutton power-on”, the transmitter is in the “non-continuous” mode (i.e. pushbutton must be pressed to operate the function), it can save power.

C. E.U. standard Power-On Mode

1. Rotate “EMS” mushroom clockwise 45° and pull out.
2. Turn rotary key switch clockwise to “ON” position.
3. Continue to turn rotary key switch to “START” position to turn on power. (after release rotary key switch, it will automatically back to “ON” position.)
4. After 3 minutes of non-operation, transmitter will send out an emergency stop signal to the receiver. When this occurs, one must turn rotary key switch counter-clockwise to the “OFF” position, then turn the key clockwise to the “ON” position, and continue to turn rotary key switch to “START” position to turn on the power.

Note: When setting is on “E.U. standard” Power-on Mode, the transmitter is in the continuous mode.

D. Software Power-On Mode

This “Power-On” mode is controlled by the software. It consists of (1) Whether the receiver Power-Off automatically when no operation for a period of time. (2) Whether a password is required to turn on power. (3) Whether an “emergency stop” signal will be sent out... etc.

4-4-2 Acceleration/Deceleration Operation

1. "R2" pushbutton is the acceleration pushbutton. "R1" pushbutton is the deceleration pushbutton.
2. When a motion is in the second speed, quick touch of acceleration pushbutton will double the speed. Repeated touch of acceleration pushbutton will increase the speed up to 4 or 5 speeds.
3. To reduce the speed, touch the deceleration pushbutton. Repeated touch of deceleration pushbutton will reduce to the second speed.

NOTE:

- (1) To accelerate/decelerate, the motion pushbutton must be depressed and held in the second speed. If motion pushbutton is released, there will be no acceleration/deceleration and speed will return to zero.
- (2) Press "R1" pushbutton to perform the "Alarm" function if the speed is reduced to the second speed.

4-4-3 Inching Operation

1. "R2" pushbutton is set for "inching" pushbutton.
2. Press and hold inching pushbutton.
3. Press any motion pushbutton to perform the inching motion.

NOTE: The other transmitter pushbutton must be released before pressing inching pushbutton.

4-4-4 Change of Frequency

This remote controller provides 3 operating frequencies. When there is interference by radio waves and the remote control cannot operate properly, the operator can change the transmitter's frequency according to the following procedures, without changing the channel in the receiver. This eliminates the trouble of climbing to the receiver.

NOTE 1: From the transmitter, one can depress the corresponding pushbutton to change operation frequency. In the meantime, LED indicator displays different colors to show the operation frequency as follows:

Operation frequency	LED Color	Corresponding pushbutton
Frequency A	Red	"Up" pushbutton
Frequency B	Yellow	"Down" pushbutton
Frequency C	Green	"Fast" pushbutton

NOTE 2: From the transmitter, one can follow to the below-mentioned procedures to check the operation frequency.

1. Press EMS mushroom.
2. Turn security key to "Off" position and then turn security key clockwise from "Off" to "On" position.
3. At this moment, LED indicator will display the corresponding color to show the present operation frequency of transmitter.

 NOTE 3: Both receiver and transmitter must be in the same operation frequency to operate properly. (e.g. both in Frequency A, or B, or C).

NOTE 4: Channels 1 to 256 can be set by Dip switch in the receiver or set by software.

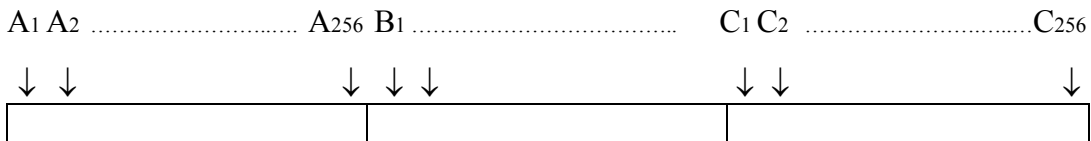

- Dip switch in the receiver is an 8-bit for 256 channels. If current setting is Channel 16, one can choose among frequency A16, B16, C16.
- Bandwidth of each section and separation between channels can be set by software. E.g. A1 = 430.000 MHz A2 = 430.025 MHz...
A256 = 436.375 MHz; B1 = 437.000 MHz; B2 = 437.025 MHz.... Etc.

4-4-4-1 Procedures for changing operation frequency:

Step	Action	Remark
1	Press EMS mushroom	1. "Up" pushbutton = Frequency A 2. "Down" pushbutton = Frequency B 3. "East" pushbutton = Frequency C
2	Turn security key to "Off" position.	
3	Depress and hold the pushbutton in accordance with The frequency that you want to change. Note: The pushbutton must be depressed and held Until step 6 is completed.	
4	Turn security key clockwise from "Off" to "On" Position.	
5	Turn security key counter clockwise from "On" to "Off" position once LED Indicator ceases flashing.	
6	Complete	
7	Power-On according to the proper procedure described previously and return to normal operation.	

4-4-5 Enter password operation

1. Rotate "EMS" mushroom clockwise 45 degrees and pull out.
2. Turn security key clockwise to "ON" position.
3. Press the pushbutton sequentially to enter password within 10 seconds.
(Remark: This time duration of "Password Complete" can be set by software. At the duration of "Password Complete" the LED indicator will flash with Green color.)
4. The buzzer of transmitter will sound one-long sound to indicate the password is correct. After buzzer, turn off Power-On according to the proper procedure and return to normal operation.
5. If password is incorrect then the buzzer will sound with two-short sounds and one-long sound. Enter the correct password again after buzzer is turned off.

NOTE 1: The function of password can be set by software in order to avoid unauthorized people to use remote controller.

NOTE 2: One must re-enter password to return to normal operation if EMS mushroom has been pressed (or "emergency stop" signal has been transmitted due to transmitter auto power off).

Chapter 5 Inspection and Maintenance

5 - 1 Inspection

Daily inspection is important and will ensure the safety of operation. Inspection should include "emergency stop" and other safety devices and functions. If there is any doubt, operation must be stopped immediately and problems must be solved before operation is resumed.

5 - 2 Maintenance

This remote control is equipped with a self-diagnostic device. During the operation and the change of batteries, self-diagnostic device will activate the warning alarm if any malfunction is detected. Operator must understand the malfunction signals and notify the maintenance personnel. Malfunctions and warning alarm are listed as follows:

NOTE: When "alarm mode" is selected as "Simple alarm mode", alarm signals are shown on the list; when "alarm mode" is selected as "Morse alarm mode", please refer to Technician's Manual.)

Malfunction Part	Error message	Alarm Signal	Remark
Transmitter	Encoder Module Malfunction	-	Alarm lasts 0.5 second repeats every 2 seconds
	RF Module Malfunction	--	Refer to Note below
	Insufficient power to operate transmitter	---	Refer to Note below
Receiver	Relay Module Malfunction	-	Alarm lasts 0.5 second repeats every 2 seconds
	Receiver/Decoder Module malfunction	--	Refer to Note below
	Power failure	---	Refer to Note below

NOTE: Each " - " indicates 0.5 second alarm. Each short interval lasts 0.5 second, and long interval lasts 2 seconds.

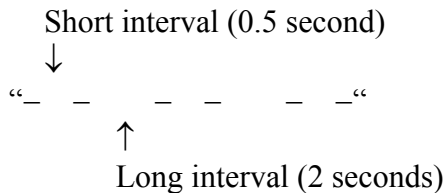

Part 2 Technician's Manual

Chapter 1 General Characteristics

1 - 1 General Specifications

- Operating Frequency : 415 - 483 MHz (set by software)
- Hamming Distance : > 4
- I.D. Code : 2^{32} ; more than 4 billion sets (set by factory, never repeated)
- Temperature Range : -30 degrees C - +75 degrees C
- Channel Spacing : 5KC/6.25KC or integral multiple (set by software)
- Maximum Operation Range : Up to 100 Meters
- Structure : Fiber-Nylon
- Protective Degree : IP - 65

1 - 2 Transmitter Specifications

- Power Supply : Four 1.5 volts Alkaline or Rechargeable AA Batteries
- RF Power : < 10 mWatts
- Modulation : $\leq \pm 2.5$ KHz; NBFM
- Pushbutton Type : Two-step Mechanical Switch
- Dimensions : 163x49x45 mm (LxWxH)
- Weight : 280 g (w/batteries)

1 - 3 Receiver Specifications

- Power Supply : AC 110V (50/60 Hz)
: (tolerance ± 10 %)
- Sensitive : -110DBm (Date Error Rate < 10^{-3})
- Image Rejection : > 60 DB
- Rejection of Adjacent Channels : > 80DB (± 20 kHz)
- Output Relays : 10A/250 VAC; 8A/30 VDC
- Dimensions : 167 x 154 x 88 mm (L x W x H)
- Weight : 1400 g (w/o cable)

Chapter 2 System Configuration

2 - 1 Transmitter Unit

Transmitter unit consists of Encoder Module and Transmitter RF Module, for transmitting "control data" to the receiver for remote control applications.

2-1-1 Encoder Module:

A micro control unit (MCU) is used for the main processing, MCU reads the pushbutton data and combines with the ID Code, Hamming Code and Function Setting. After producing control data by encoding, it generates TXFSK signal to transmitter's RF module via FSK circuit.

2-1-2 Transmitter RF Module:

The sequence of RF module is shown as follows:

Encoder to TXFSK to modulates a RF carrier to amplification to antenna.

This RF Module uses Phase Locked Loop (PLL), Voltage Controlled Oscillator (V.C.O.) with lowest side-band noise, SMT advanced technologies. It has power-saving, high efficiency, high reliability and low harmonic NBFM transmitting circuit.

2-1-3 Parts Name and Illustration

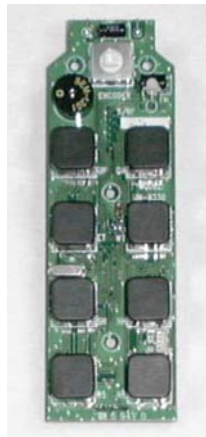

Figure 2-1-1 Encoder Module



Figure 2-1-2 Transmitter RF Module

2 - 2 Receiver Unit

Receiver unit consists of Receiver/Decoder Module and Relay Module. This unit receives the control data from the transmitter, decodes the data, generates control command, and drives relay circuit to control the motions of cranes (or the lifting machine).

2-2-1 Receiver/Decoder Module:

This module consists of high frequency receiver circuit and micro control unit. Its main functions are to receive RF signal from transmitter, to detect and correct the received data message, to decode and to send commands to the relay module. This module has high-receiving gain, high-signal selectivity, high-image rejection rate, and low-noise figure. In addition, this module uses special design of "Frequency Deviation Direction Indicator" (FDDI) to eliminate the adverse effect of environmental change, such as temperature.

2-2-2 Relay Module:

This module receives and processes control commands to drive corresponding relay in order to control the motion of cranes (or the lifting machine). The operation safety is especially important. This module consists of relay operating voltage test circuit, and the protection circuit for micro control unit, to ensure operation safety.

2-2-3 Parts Name and Illustration

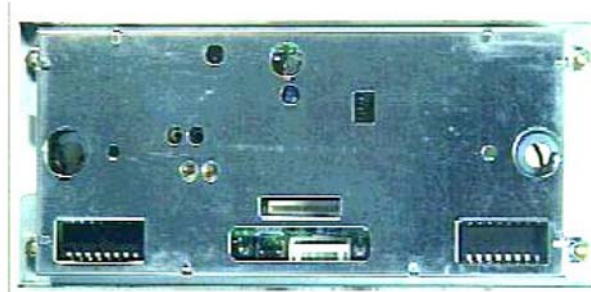

Figure 2-2-1 “Receiver/Decoder” Module

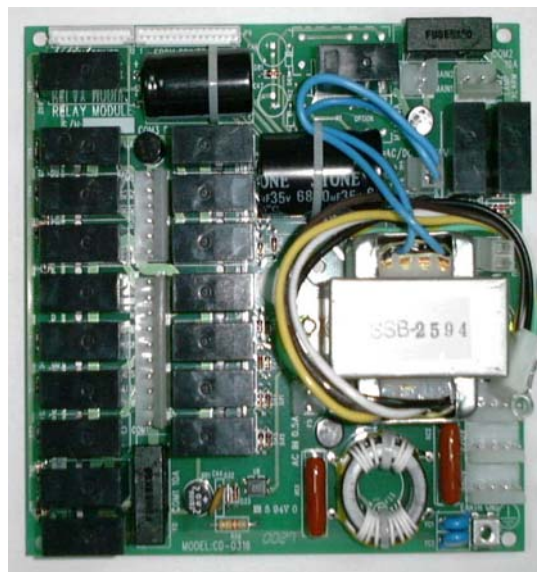
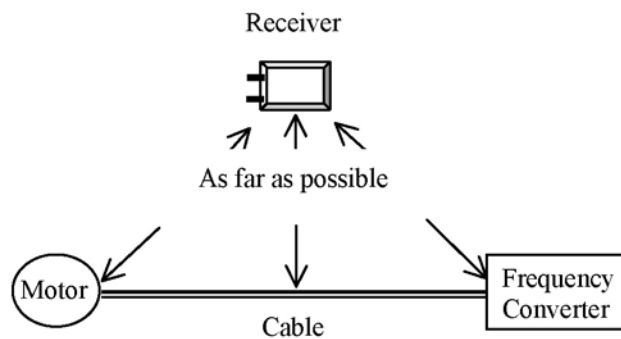

Figure 2-2-2 Relay Module

Chapter 3 Installation and Function Setting

3 - 1 Precautions during installation

1. Observe all safety precautions when climbing the crane.
2. Turn off the main power source of cranes before installation to avoid electric shock.
3. Receiver must be installed in the way that it will not touch any part of the building during the operation.
4. Receiver must be fastened safely.
5. Two external antennas must be used when receiver is installed in a metal box.
6. Before installation, inspect the crane's safety devices, and make sure everything is in proper working condition.
7. Make sure you understand the crane circuits and power distribution as well as the function setting of remote controller, to avoid incorrect wiring.
8. To avoid any interference, the Receiver must be away from motors, frequency converter and power cable (show as below).



9. The Receiver should be installed on the top of the electrical control box. To mount the receiver inside the electrical control box is not correct.

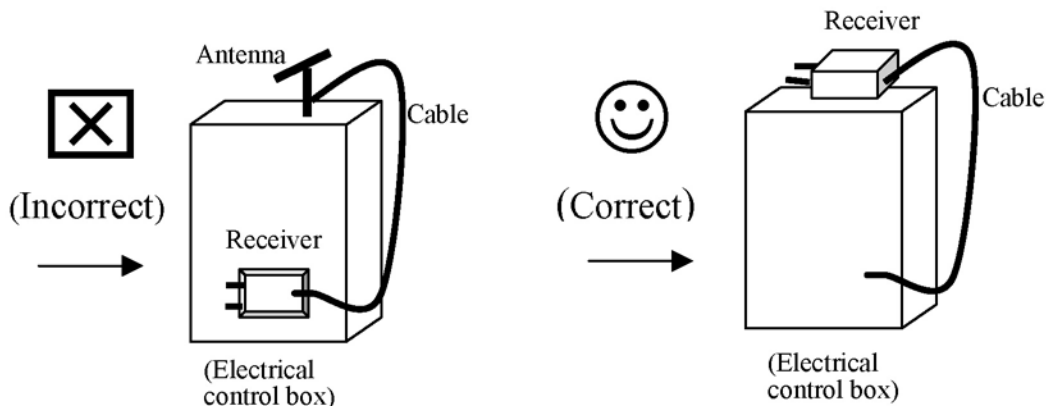

3 - 2 Transmitter Installation Instructions

3-2-1 Installation of batteries in the transmitter:

Put batteries in proper direction into battery compartment, and put screws in the bottom cover of the Transmitter, then it will sound two long sounds ("– –"): "–" indicates 0.5 second sound and the short interval lasts 0.5 second) to indicate proper installation.

3-2-2 Installation of function setting software in the transmitter:

When change in new transmitter or change remote controller's function settings (such as change receiver's function settings, or channel dip switch settings), one must follow the procedures below (please refer to section 3-4) to install the function setting software in the transmitter, in order to pair the transmitter and receiver.

3 - 3 Receiver Installation Instructions

3-3-1 Preparation for Installation

1. Provide all necessary tools.
2. Select a proper location.
 - a. Select a stable place.
 - b. Select a place where you can see the Receiver or Antenna.
 - c. Select a place where there is no spark, e.g. keep away from motors, relays, magnetic switch and power cables.
 - d. Keep away from high-voltage wiring and device.
 - e. **The Receiver's box must be at least 3 cm away from other obstacles.**



3. Installation of proper power source
The input power source for receiver is 110 VAC; 50/60 Hz. **After power source is confirmed, one must connect the connector of initial coil of transformer to the relay module properly.**

3-3-2 Installation Sequence

1. Turn off the main power for crane.
2. Find a proper place for the receiver.
3. Drill the holes for screw, install receiver and then fix the receiver with 6 mm screw nut on vibration-resistant mount.
4. Connect cables to the control circuit of crane according to the receiver's wiring table and control contacts diagram.

Note:

- 1) **Inspect and make sure that all wires are connected correctly.**
 - 2) **Earth ground for remote control and crane must be properly connected to ensure safety.**
5. **Secure the cables between the receiver and crane so that cable sheath will not wear out due to the vibration of the crane.**
 6. **Open the top cover of the receiver and turn Relay module's Run/Test switch to "Test" position.**
 7. **Turn on the main power for crane.**
 8. **Operate the transmitter to test every function and make sure they are all correct (read by LED indicator).**
Note: When Run/Test switch is set to "Test" position, relay will not function, but LED will display.
 9. **Turn Run/Test switch to "Run" position and secure the top cover to the receiver with screws.**
 10. **This completes the installation of the receiver.**

3-3-3 Wire Diagram

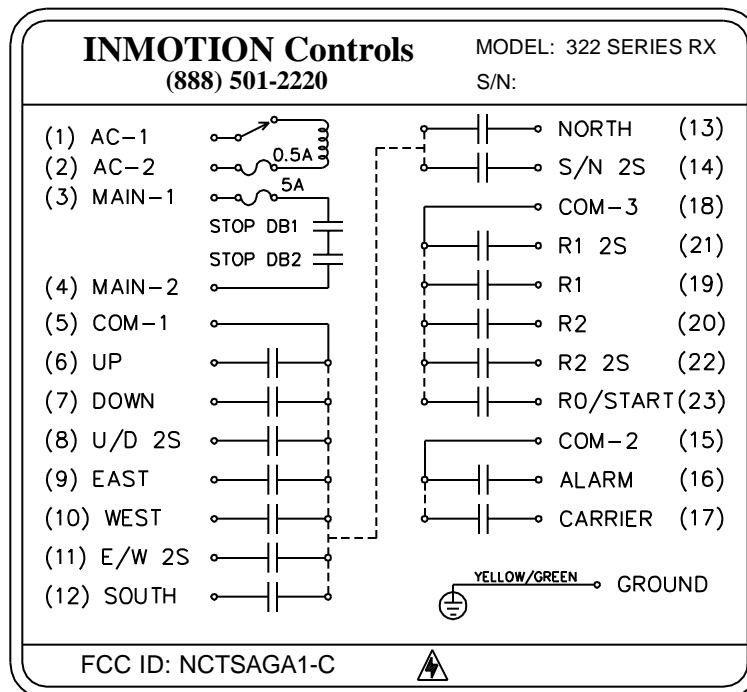

3 - 4 Copier guide

When changing the remote controller's function settings (for example: direct loading of function setting software from PC into the transmitter). One must follow the Copier guide to install the function setting software in the receiver, in order to pair the receiver and transmitter.

3 - 5 Password setting

The function of password code can be set by pushbutton or by software in order to avoid unauthorized people to use remote controller. If select "by pushbutton" then the procedure of password code setting is as below:

1. Depress EMS mushroom and turn security key to "off" position.
2. Depress and hold "UP" & "DOWN" two pushbuttons and then turn key from "off" to "on" position simultaneously. At this time, LED will flash with red and green color alternately for 10 seconds.
3. Press the pushbutton sequentially to key in new password within 10 seconds. The buzzer will sound three-long sounds if the procedure of setting password is finished. The length of password is four-digits, for example: Up, Up, Down, Up.
4. Rotate EMS mushroom clockwise 45° and pull out, enter new password to turn on transmitter.

3 - 6 Radio remote setting

The operation procedures mentioned herein refer to the process of the transmitter's remote wiring of function setting software into the receiver. It means that to preserve the required setting in transmitter in advance then sends out the radio signal to receiver at workshop. This performance can eliminate the trouble of climbing to the receiver. Radio setting includes "Channel setting" and "Function Setting".

Note:

1.  Before operating, one must make sure that all of the relays are at "off" status (i.e. the receiver is in "Power-Off" mode).
2. Before operating, one must make sure that the communication status between transmitter and receiver is at good condition.

3-6-1 "Channel setting" by radio:

1. Using PC or Maintenance Kit to install channel setting into transmitter in advance.
2. Depress EMS mushroom and turn security key to "off" position.
3. Depress and hold "East" & "West" two pushbuttons and turn security key from "off" to "on" position simultaneously.
4. Release "East" & "West" two pushbuttons. At this time, LED indicator will flash with yellow and green color alternately.
5. After the alarm of receiver sound one-long sound "-" (one-long sound means that channel setting is completed), turn security key from "on" to "off" position.
6. "Power-On" according to the proper procedure and return to normal operation.

3-6-2 "Function setting" by radio:

1. Using PC or maintenance kit to install function setting into transmitter in advance.
2. Depress EMS mushroom and turn security key to "off" position.
3. Depress and hold "Up" & "East" two pushbuttons and turn security key from "off" to "on" position simultaneously.
4. Release "Up" & "East" two pushbuttons. At this time, LED indicator will flash with yellow and red color alternately.
5. After the alarm of receiver sound two-short sound and one-long sound "••-" (two-short sound and one-long sound means that function setting is completed), turn security key from "on" to "off" position.
6. "Power-On" according to the proper procedure and return to normal operation.

3-7 Software Setting

In addition to the dip switch setting mentioned in section 3-5, this remote control system can be set according to the working condition and operator's need for the following promotes: pushbutton function, "Bypass EMS" function, search function, "Passive EMS" function Etc. This enables the remote controller to perform the most elective operation and to provide the safest operation. Please refer to the manual for software setting.

Chapter 4. Troubleshooting

4 - 1 Self-Diagnostics

In order to simplify the maintenance, this remote control system has been designed with the built-in self diagnostics circuit in the transmitter and receiver. As long as the micro control unit is in proper working condition, malfunctions in pushbutton, RF circuit, relay and relay driver circuits (including relay coil and relay contact) can be detected. When malfunction occurs, transmitter or receiver will generate a simple and clear alarm. Not only the operator and maintenance personnel can fully understand the condition of remote controller, but can also reduce the maintenance time by following the error message for repair.

Note:

1. Malfunction Alarm mode can be set by software for the "Simple Alarm Mode" or "Morse Alarm Mode". Simple Alarm Mode was discussed in Operator's Manual. The following explains the "Morse mode" for the error message.
2. Alarm (error message) is shown according to Morse code. "•" Indicates short alarm for a duration of 0.26 second; "-" indicates long alarm for a duration of 0.78 second; interval between alarms is 0.26 second. An example for transmitter pushbutton error message is shown as follows:

“ • • - • • • - • ”
↑ ↑ ↑ ↑
.026 sec .026 sec .078 sec 1.5 sec

3. When an error message is detected by receiver or transmitter's self-diagnostics, an alarm will sound and "Power-OFF" will be activated. Unless the malfunction has been corrected, it will be impossible to Power-On the controller.
4. Technicians for maintenance can use error message. However, we recommend the technician replace only the module. The defective module should be returned to our distributor for the repair of components. This will eliminate further damage to the controller.
5. If you do not understand the error message from the transmitter or receiver, or the signal is not listed in this manual, please contact our distributor for clarification and recommendation.

4-1-1 Transmitter's Malfunction and Correction

Item	Error Message		Description	Correction
		Morse Code		
1	C	– • – •	Malfunction of EPROM Memory in the encoder Module; can't read/write.	1. Replace encoder module. 2. Perform the installation of software (refer to Section 3-4)
2	D	– • •	EPROM in the encoder Doesn't have operation Software or software is incomplete.	Perform the installation of software (Refer to section 3-4)
3	F	• • – •	Malfunction of pushbutton (short)	1. Replace encoder module. 2. Perform the installation of software (refer to Section 3-4)
4	R	• – •	Batteries dead	Replace batteries
5	S	• • •	RF module malfunction	Replace RF module Note: RF Module's Frequency must be set the same as that of the receiver.

Note:

1. If the malfunction of pushbutton is occurred the buzzer will sound and the LED indicator will flash with red color simultaneously when the power is reset (e.g. change of battery).
During operation the transmitter will perform self-diagnostics when EMS mushroom is pressed. If the malfunction of item 3 is occurred, only LED indicator (flash with red color) will indicate the error message when you press the EMS mushroom.
2. The alarm for other items will sound only when you push the pushbuttons or when the power source is reset (e.g. change of battery).

4-1-2 Receiver's Malfunction and Correction

Item	Error Message			
		Morse Code		
1	A	• –	"UP" relay coil damage	Replace Relay Module
2	B	– • • •	"U/D 2S" relay coil damage	
3	C	– • – •	"DOWN" relay coil damage	
4	D	– • •	"EAST" relay coil damage	
5	E	•	"E/W 2S" relay coil damage	
6	F	• • – •	"WEST" relay coil damage	
7	G	– – •	"SOUTH" relay coil damage	
8	H	• • • •	"S/N 2S" relay coil damage	
9	I	• •	"NORTH" relay coil damage	
10	Q	• – – •	"MAIN" relay coil damage	
11	U	– – • –	Relay contact is jammed (can't open) at COM1.	
12	R	• – •	The voltage of input power is over the tolerance.	<ol style="list-style-type: none"> 1. Disconnect the cable from the receiver. 2. Turn off the main power of crane and check the voltage of the input power. 3. Check whether the voltage select plug is at the correct position. 4. Inspect and make sure the power is normal before resuming operation.
13	S	• • •	RF circuit malfunction	Replace "Receiver/decoder" module.
14	Y	– • – –	Interfered by the same model remote control.	Change to a new frequency.

15	1	● - - - -	Interfered by the same frequency of other radio signal.	<ol style="list-style-type: none"> 1. If interference is not serious, "Power-On" the Remote controller when interference is over. 2. If interference is serious, change to new frequency. (Refer to section 4-4-4 in Operator's Manual.
16	Z	- - ● ●	EPROM in the Receiver/ Decoder doesn't have operation software or software is incomplete.	Contact distributor installation of new operation software

Note:

1. When receiver's self-diagnostics detects a malfunction, alarm will continue, unless the malfunction has been corrected or the power to the receiver has been disconnected.
2. The receiver can be set by the software to alarm or not, when error occurred relating to item 14, 15.
3. The receiver can be set by software to close the relative action (i.e. "Relay-Off") or "Power-Off" automatically, when the error occurred relating to items 14, 15. In the other items, the receiver will enter into the Auto Power-Off mode.
4. This receiver contains Auto Gain Control circuit with high sensitivity; when not in operation, it may receive weak signal from unknown sources. As long as the interference does not occur very often, it will not affect the normal operation. No frequency change is necessary.

4 - 2 Malfunction Identification.

When remote control can't function properly (e.g. Receiver can't function correctly after pressing the pushbutton of the transmitter) and there is no alarm for malfunction information, please follow the procedures below to check the malfunctions.

Item	Malfunction	Action Required
1	Transmitter's LED and buzzer do not react at all.	<ol style="list-style-type: none"> 1. Make sure battery power is normal: <ol style="list-style-type: none"> a. Check battery's direction. b. Check battery's condition. 2. Make sure micro control unit (MCU) is normal: <ol style="list-style-type: none"> a. Press EMS mushroom and turn security key to "OFF" position. b. Remove battery cover and take out batteries, then press and release any one of pushbuttons on Transmitter. c. Put batteries into battery compartment and screw on battery cover. At this time, buzzer should generate two-long sounds. Otherwise, the MCU is out of order or the power connecting wire is abnormal. 3. Return for repair.

2	Transmitter is normal but receiver's buzzer doesn't react at all.	<ol style="list-style-type: none"> 1. Make sure the receiver's power source is normal: <ol style="list-style-type: none"> a. Inspect "Receiver/Decoder" to see if the SQ indicating light is on and the Diversity's ANT A and ANT B flash alternatively. b. Inspect AC power fuse and DC power fuse to see if the fuse is burnt out. If necessary, turn off the main power and replace the fuse. 2. Make sure the "Receiver/Decoder" module and "Relay" module are wired correctly. 3. Make sure the output fuse of the relay is not burnt out. Replace fuse if necessary. 4. Make sure the Alarm's relay is not out of order. (If the Alarm's LED is on, it means the relay is out of order.) 5. Return for repair.
3	Certain motion does not work.	<ol style="list-style-type: none"> 1. Make sure the output fuse of the relay is not burnt out. Replace fuse if necessary. 2. Make sure the original control system of crane works properly. If not, ask for the original manufacturer to repair. 3. Return for repair.

SUPPLEMENT

1. Selective Power Supply for Series 322 as illustrated below:

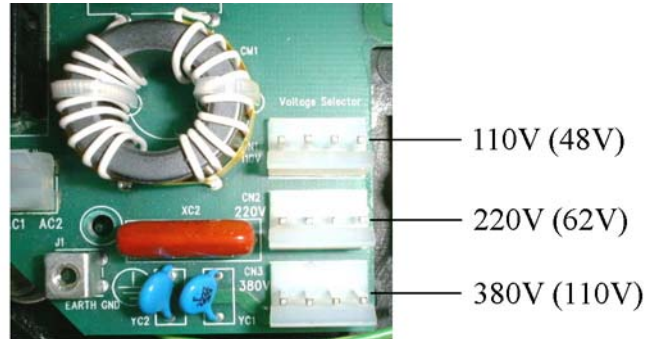

1-1 There are 3 kinds of voltage (110V/220V/380V) supplied in Series 322 could be set as required before shipment, or follow the procedures to change the voltage.

1-1-1 Turn off the Receiver.

1-1-2 Pull out the power source plug from the previous voltage position

1-1-3 Plug in the power source plug to the voltage you need

1-1-4 Complete

Note: If the voltage you need is 48V/62V/110V, please contact distributor.

2. Attentions for “R1/R2 pushbutton” function setting of Series 322.

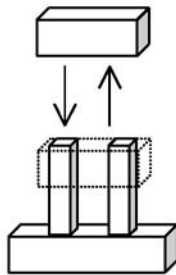

2-1 As the above picture shows, if “R1/R2 pushbutton” required as “INTERLOCK”, the connector must be taken out from the 2-pin socket on LED board of Series 322 Receiver; if “NON-INTERLOCK”, must plug in the connector.

2-2 If “R1/R2” is “INTERLOCK”, there will be noted as below:

Item	Title	Content	Description	Remark
1	R1	No Function	Okay	Recommended
	R2	Normal		
2	R1	No Function	Okay	Recommended
	R2	Toggle		
3	R1	No Function	Okay	Recommended
	R2	Inching		
4	R1	Normal	Okay	Recommended
	R2	Inching		
5	R1	Deceleration	Okay	Recommended
	R2	Normal		
6	R1	Deceleration	Okay	Recommended
	R2	Toggle		
7	R1	Deceleration	Okay	Recommended
	R2	Inching		
8	R1	Normal	The motions of R1 and R2 can't operate simultaneously.	Caution
	R2	Normal		
9	R1	Toggle	When press R1 pushbutton, the relay of R1/R2 2S is energized. Inching function for R2 pushbutton is okay.	Caution
	R2	Inching		
10	R1	No Function	When acceleration, press & release R2 pushbutton twice can accelerate to 4-speed. If press more than twice it will go back to 2-speed.	Caution
	R2	Acceleration		
11	R1	Normal	The motions of R1 and R2 can't operate simultaneously.	Caution
	R2	Toggle		
12	R1	Normal	For R1, only can reach 2-speed, the rest including UP/DOWN/EAST/WEST/SOUTH/NORTH can accelerate to 4-speed, but if press and hold R1 pushbutton at the same time, it will go back to 2-speed, after release R1 pushbutton, then up to 4-speed again.	Not recommended
	R2	Acceleration		
13	R1	Toggle	The motions of R1 and R2 can't operate simultaneously.	Not recommended
	R2	Normal		
14	R1	Toggle	The motions of R1 and R2 can't operate simultaneously.	Not recommended
	R2	Toggle		

15	R1	Toggle	When press R1 pushbutton, the relay of R1/R2 2S is energized, then acceleration for R2 pushbutton is ineffective. To do the acceleration, first press & release R2 pushbutton twice can accelerate to 4-speed, but if press and release R1 pushbutton at the same time, it will go back to 2-speed, if press and release R1 pushbutton again, it will up to 4-speed again.	Not recommended
	R2	Acceleration		
16	R1	Deceleration	When acceleration, press & release R2 pushbutton twice can accelerate to 4-speed. If press more than twice, it will go back to 2-speed. Deceleration function for R1 pushbutton is okay.	Not recommended
	R2	Acceleration		

2-3 If “R1/R2” is “NON-INTERLOCK”, there will be noted as below:

Item	Title	Content	Description	Remark
1	R1	No Function	Okay	Recommended
	R2	Normal		
2	R1	No Function	Okay	Recommended
	R2	Toggle		
3	R1	No Function	Okay	Recommended
	R2	Inching		
4	R1	Normal	Okay	Recommended
	R2	Inching		
5	R1	Deceleration	Okay	Recommended
	R2	Normal		
6	R1	Deceleration	Okay	Recommended
	R2	Toggle		
7	R1	Deceleration	Okay	Recommended
	R2	Inching		
8	R1	Normal	Okay	Recommended
	R2	Normal		
9	R1	Toggle	When press R1 pushbutton, the relay of R1/R2 2S is energized. Inching function for R2 pushbutton is okay.	Caution
	R2	Inching		
10	R1	No Function	When acceleration, press & release R2 pushbutton three times can accelerate to 5-speed.	Caution
	R2	Acceleration		

11	R1	Normal	Okay	Recommended
	R2	Toggle		
12	R1	Normal	For R1, can only reach 1-speed, if one of the rest including UP/DOWN/EAST/WEST/SOUTH/NORTH can accelerate to 4-speed.	Not recommended
	R2	Acceleration		
13	R1	Toggle	If R2 pushbutton is pressed and held at 2-speed, the motion of R1 is ineffective. If R1 pushbutton is pressed & released as “Toggle”, then press R2 pushbutton can only reach 1-speed.	Not recommended
	R2	Normal		
14	R1	Toggle	Okay	Recommended
	R2	Toggle		
15	R1	Toggle	If press R1 pushbutton as “Toggle” first, then press R2 pushbutton three times can make the rest of UP/DOWN/EAST/WEST/SOUTH/NORTH reach 4-speed. If not, press R2 pushbutton three times can make the rest of UP/DOWN/EAST/WEST/SOUTH/NORTH reach 5-speed.	Caution
	R2	Acceleration		
16	R1	Deceleration	Okay	Recommended
	R2	Acceleration		

3 Improvements on functions of Series 322 as below:

3-1 The pushbuttons of Series 322 including UP/DOWN/EAST/WEST/SOUTH/NORTH have the new function setting of “ON/OFF”.

3-2 The function of ALARM is only set and controlled by the Rotary key switch of Series 322, not set and controlled by R1.