



INMOTION Controls Inc.

Industrial Radio Remote Control

**INMOTION Series 310
INMOTION Series 310-1/Both/2
INMOTION Series 310-3C
INMOTION Series 310-T/H-C**

User's Manual

Safety/Reliability/User-Friendly

April, 2014

This device complies with part 15 of FCC Rules. Operation is subject to the following two conditions; (1) This device may not cause harmful interference, and (2) this device must accept any interference received, including interference that may cause undesired operation.

**FCC ID: NCT048L10 IC: 2802A-048L10
CE 0678**

WARRANTY

INMOTION Controls, Inc. guarantees that this product meets its published specification at the time of shipment from the factory. Under proper installation, it should work as expected. However, INMOTION Controls, Inc. does not guarantee that operation of the 310 Series Radio Control System is error-free or without interruption.

This equipment is warranted against defects in materials and workmanship for a period of one year from the date of shipment. During the warranty period, INMOTION Controls, Inc. is responsible for necessary repairs, as long as the product can be proved to be defective.

For warranty service or repair, this product must be returned to our factory. Customer is responsible for shipping charges to INMOTION Controls, Inc., while INMOTION Controls, Inc. will pay return shipping charges.

This warranty does NOT include consumable parts, such as joystick, batteries, fuses, buttons, and relays or damage from normal wear and tear. Furthermore, this warranty does NOT cover defects caused by misuse, neglect, accident, failure to follow instructions, improper installation, improper or insufficient maintenance, unauthorized modification, unsuitable operating environment, improper operation, ignorance of environmental specifications, improper software/interfaces, fire, or acts of God.

- No other warranty is expressed or implied, except for the above mentioned
- The remedies provided herein are the buyers' sole and exclusive remedies.
- INMOTION Controls, Inc. shall not be liable for any direct/indirect, special, incidental or consequential damages.

OPERATING PRECAUTIONS

ATTENTION

- Due to the complex nature of the equipment, it is necessary to read the entire manual before installation.
- Never dismantle equipment by any unauthorized personnel, or equipment may be damaged.
- This Manual is for reference only; please call your distributor if further assistance is required.
- This equipment has been strictly tested for quality before delivery from our factory. However, it must not be used in extremely dangerous situations, or where damage may result.
- After operating, please shut off main power in Crane and the power to Receiver.
- Transmitter should be placed safely when not in use to avoid accidental pressing of buttons.
- The Crane should be equipped with main power Relay, Limit Switch and other required safety devices.
- The GND (ground) of Receiver must be connected with metal part of Crane, or electrical shock will occur.
- Do not use this device during electrical storm, or high electrical interference conditions.
- Ensure Transmitter batteries are in good condition and power for Receiver is normal.
- Installation and maintenance should be done only while the Crane's main power and Receiver's power are OFF, to prevent electrical shock.
- Contents of the Manual may be amended by the manufacturer without notice.

PRECAUTIONS

- After Operating Series 310, please press EMO (Emergency Off) mushroom and turn the keyswitch to the “Off” to shut off main power in the Crane & Receiver.
- Stop operating when slow-response occurs due to insufficient Transmitter power, beyond the remote control range, or severe interference.
- Remove the batteries when the equipment won't be used for a long period.
- Operators must be in good health and have good judgment in regards to safety.
- Remote Control operator must have adequate training and related license to avoid danger.
- Series 310 Transmitter is durable and weather-resistant, but care should be taken not to subject it to severe impact or pressure.
- Series 310 is suitable for use in diverse industrial environments, and adequate operating and maintenance will extend system's life.
- Check EMO mushroom and the other security functions of Series 310 system before daily operation.
- Press EMO mushroom when malfunctions or abnormal conditions occur.
- Operator must be familiar with the following Emergency Procedures before operating.

EMERGENCY PROCEDURES

In case of emergency, please follow the steps below and ask the distributor for service immediately.

- Press EMO mushroom
- Remove the batteries
- Shut off the main power of the Crane and discontinue the operation

Contact the distributor to find out possible causes.

STANDARD ACCESSORIES

A standard and full set of Series 310 consists of:

(1) Transmitter, 2 units

(2) Receiver, 1 unit

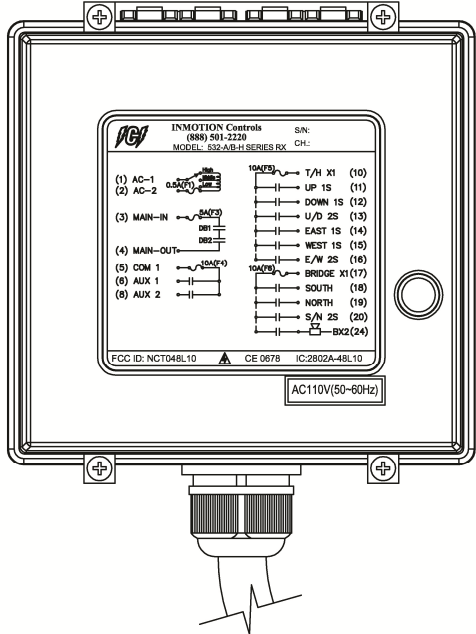
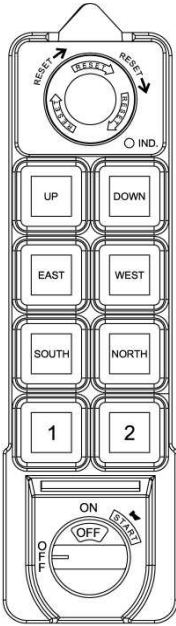

Note:

Inmotion Series 310 Shown. Models vary depending on options.

OPERATION

TRANSMITTER CONFIGURATION

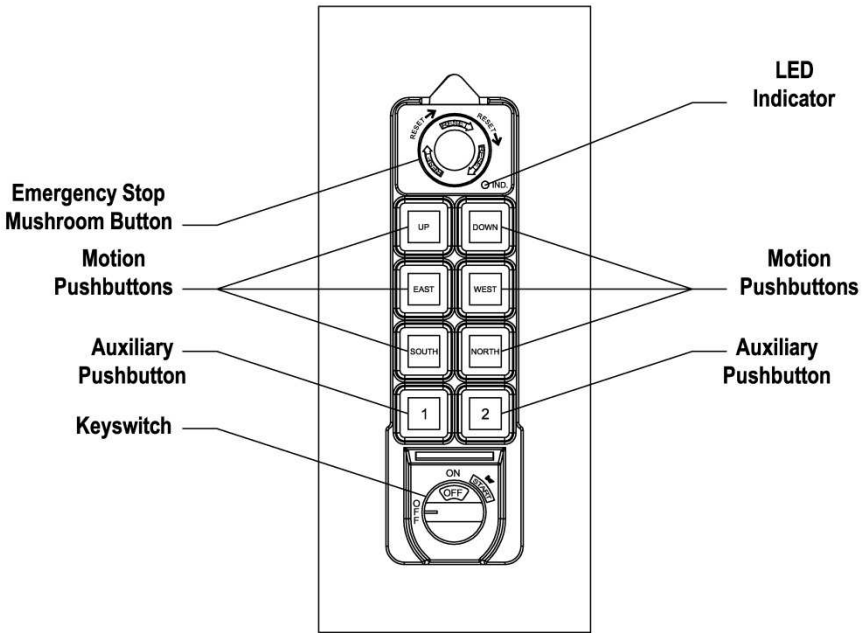

Note:

Inmotion Series 310 Shown. Models vary depending on options.

RECEIVER CONFIGURATION

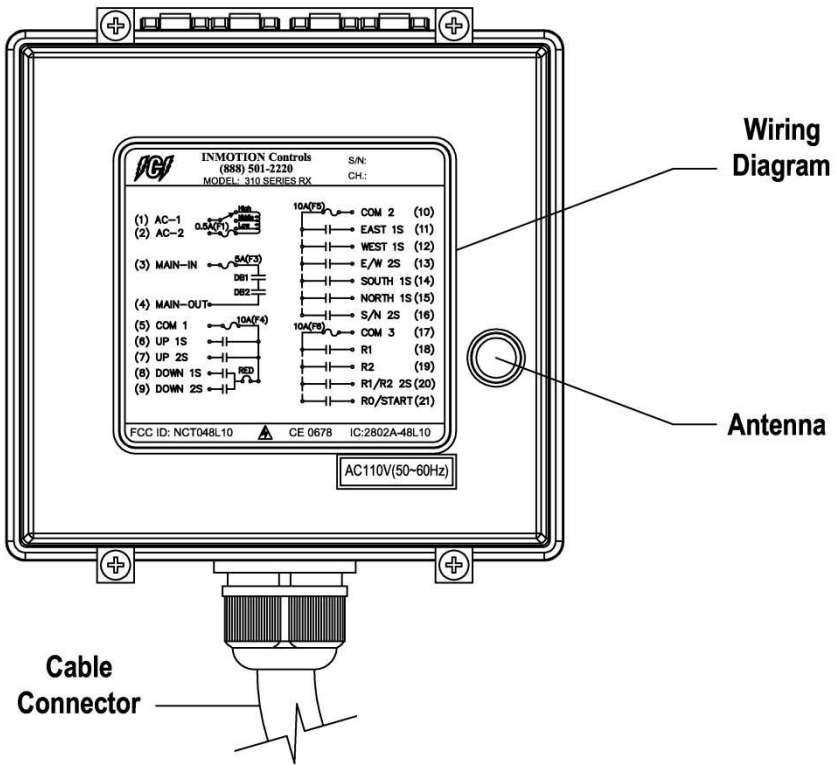

Note:

Inmotion Series 310 Shown. Models vary depending on options.

GENERAL OPERATION

- Turn on the main power switch of the equipment (Crane).
- Install 2 AA batteries in the battery box in the Transmitter. Make sure the polarity is correct.
- Attach Transmitter battery door with screws.
- Insert security key in the “OFF” position.
- Turn the keyswitch clockwise to the “ON” position, then continue to turn it to the “START” position to power-on.
Note: LED indicator will flash red if proper procedures are not followed.
- Operate Transmitter by pressing each pushbutton.
- After operation, perform the following procedures in sequence:
 - (1) Press EMO mushroom
 - (2) Turn the keyswitch to the “OFF” position.
 - (3) Remove key and keep the transmitter in a safe place.
 - (4) Switch main power off to the equipment (Crane).
 - (5) Remove batteries if not used for a long period of time.**Note:** Transmitter has power indicating functions with LED display.
 - ← “Green Color” – The LED will flash green when battery power is sufficient.
 - “Red Color” – The LED will flash red when the power is low.
 - The operating distance will become shorter and intermittent when the batteries are low.
 - Replace with new batteries when battery power is low.

! DO NOT USE RECHARGEABLE BATTERIES !

RECEIVER VOLTAGE SELECTION

There are two types of power voltages (DC and AC) available for the Series 310.

1) DC Type:

Input Voltage: 12~24 VDC

Relay Contact: 10A-36 VDC

2) AC Type:

Three different AC transformers:

48/110/220V, 48/220/380V, 110/220/380V.

Please disconnect the Receiver's power, select the proper voltage, and plug in the connector. See picture below.

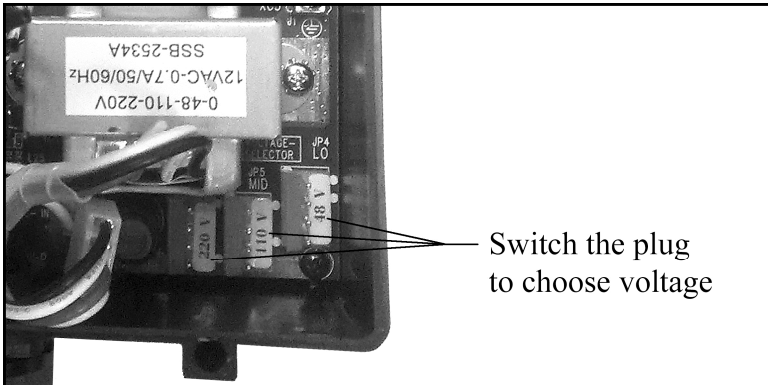

Note: Standard Systems are 48/110/220 VAC. If any others are required, please specify when ordering.

CHANGING THE FREQUENCY

It is easy to change the frequency of the Series 310 simply by replacing corresponding frequency crystals in both the Transmitter and the Receiver.

Instructions:

1. Pry up the crystal with a flathead screwdriver.
2. Remove the crystal from the system.
3. Use needle nose pliers to straighten both pins of the new crystal.
4. Insert the new crystal vertically into the PC board.
5. Press the new crystal down into the socket.

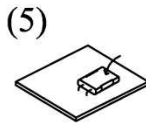
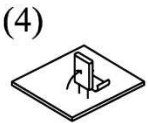
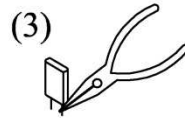
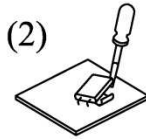
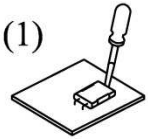

ATTENTION :

The Transmitter frequency will be different from the Receiver frequency. For example, the transmitter crystals are labeled T01 thru T40 and receiver crystals are labeled R01 thru R40.

FREQUENCY CHART

Ch	Freq. Mhz	Ch	Freq. Mhz	Ch	Freq. Mhz	Ch	Freq. Mhz
1	310.0325	11	312.7075	21	315.3825	31	318.0575
2	310.3000	12	312.9750	22	315.6500	32	318.3250
3	310.5675	13	313.2425	23	315.9175	33	318.5925
4	310.8350	14	313.5100	24	316.1850	34	318.8600
5	311.1025	15	313.7775	25	316.4525	35	319.1275
6	311.3700	16	314.0450	26	316.7200	36	319.3950
7	311.6375	17	314.3125	27	316.9875	37	319.6625
8	311.9050	18	314.5800	28	317.2550	38	319.9300
9	312.1725	19	314.8475	29	317.5225	39	320.1975
10	312.4400	20	315.1150	30	317.7900	40	320.4650

BATTERIES

Two AA size alkaline batteries are required for the Transmitter.

The LED will flash green when the battery power is sufficient.

The LED will flash red when the battery power is low.

- The operating distance will become shorter and intermittent when the battery is low.
- Replace with new battery when battery power is low.

! DO NOT USE RECHARGEABLE BATTERIES !

INSTALLATION NOTES

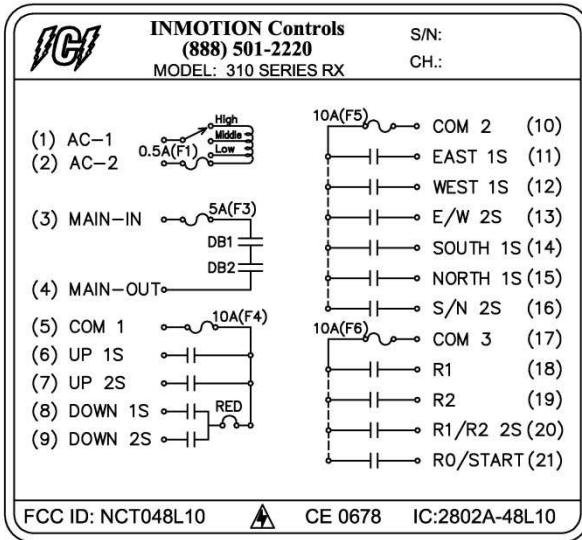

INMOTION 310 INMOTION 310 1/Both/2

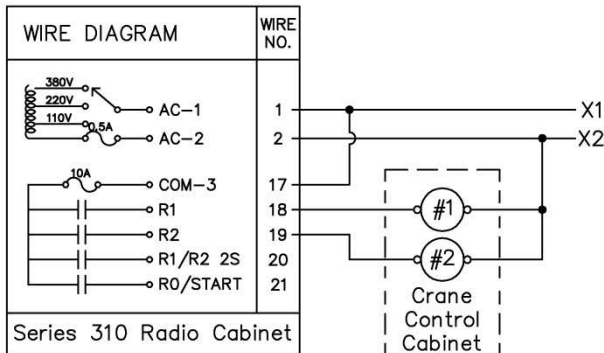

INMOTION 310 1/Both/2 Option

1. System must be programmed for this option.
2. Connect wire # 17 to X1.
3. Connect wire # 18 to relay coil of selector relay #1.
4. Connect wire # 19 to relay coil of selector relay #2.

NOTE: INMOTION 310-3C & 310-T/H-C Similar.



INMOTION Controls
(888) 501-2220
 MODEL: 310-3C SERIES RX

S/N:
 CH.:

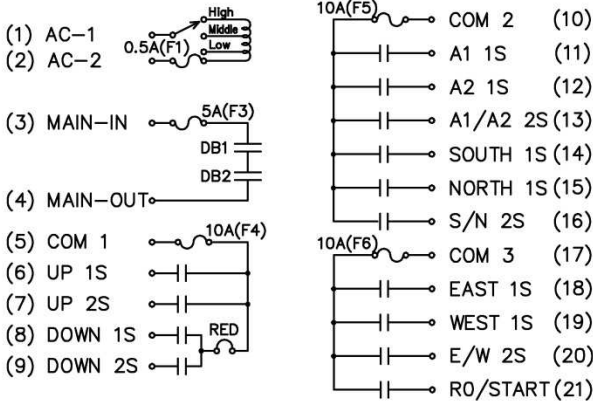

FCC ID: NCT048L10  CE 0678 IC:2802A-48L10

INMOTION 310-3C



INMOTION Controls
(888) 501-2220
 MODEL: 310-T/H-C SERIES RX

S/N:
 CH.:

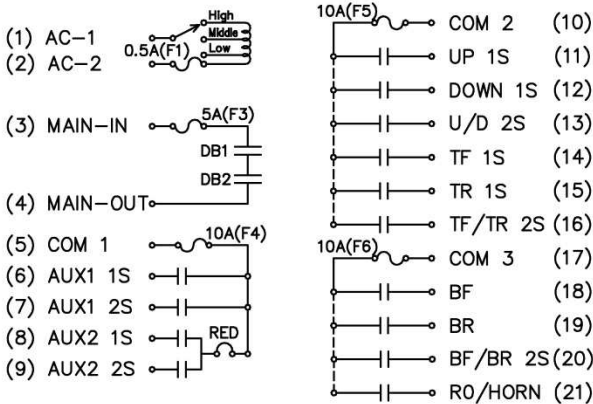

FCC ID: NCT048L10  CE 0678 IC:2802A-48L10

INMOTION 310-T/H-C

**Do You Have a
Harsh Environment?
Are Your Operators
Tough on Transmitters?**



**Try Our Neoprene
Rubber Boots**