

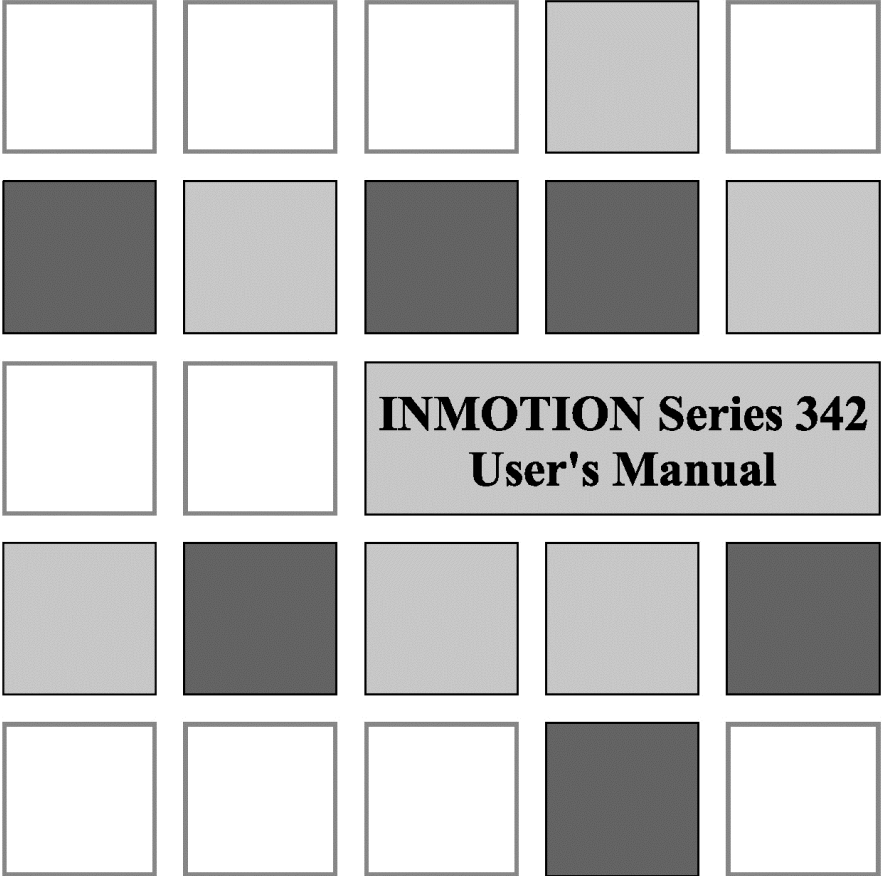

INMOTION Controls Inc.

Industrial Radio Remote Control



Safety/Reliability/User-Friendly

October, 2014

Contents

Warning and Caution.....	2
Warranty.....	3
Important Information Before You Start.....	4
Precautions.....	5
Emergency Procedures.....	5
Specification.....	6
Transmitter Overview.....	7
Receiver Overview.....	8
General Operation.....	9
➤ Getting Started.....	9
➤ Transmitter LED Indicator.....	10
➤ Changing Receiver Input Voltage.....	11
Frequency Chart.....	12
Installation Notes.....	13
Receiver Wiring Diagram.....	14

Warning and Caution

The following symbols may be found on the product or throughout the documentation.

Symbol Description



Refer to Manual

Refer to the user manual for additional information when marked with this sign.



Dangerous Voltage

Indicates the presence hazardous voltage. Unsafe practice could result in severe personal injury.



Warning

Denotes a hazard. Included text gives proper procedures. Failure to follow instructions could result in severe personal injury and/or property damage.



Caution

Denotes a hazard. Included text gives proper procedures. Failure to follow instructions could result in minor personal injury and/or property damage.

This device complies with part 15 of FCC Rules. Operation is subject to the following two conditions; (1) This device may not cause harmful interference, and (2) this device must accept any interference received, including interference that may cause undesired operation.

**FCC ID: NCT081K IC: 2802A-081K
CE 0470**

WARRANTY

INMOTION Controls, Inc. guarantees that this product meets its published specification at the time of shipment from the factory. Under proper installation, it should work as expected. However, INMOTION Controls, Inc. does not guarantee that operation of the 342 Series Radio Control System is error-free or without interruption.

This equipment is warranted against defects in materials and workmanship for a period of one year from the date of shipment. During the warranty period, INMOTION Controls, Inc. is responsible for necessary repairs, as long as the product can be proved to be defective.

For warranty service or repair, this product must be returned to our factory. Customer is responsible for shipping charges to INMOTION Controls, Inc., while INMOTION Controls, Inc. will pay return shipping charges.

This warranty does NOT include consumable parts, such as joystick, batteries, fuses, buttons, and relays or damage from normal wear and tear. Furthermore, this warranty does NOT cover defects caused by misuse, neglect, accident, failure to follow instructions, improper installation, improper or insufficient maintenance, unauthorized modification, unsuitable operating environment, improper operation, ignorance of environmental specifications, improper software/interfaces, fire, or acts of God.

- No other warranty is expressed or implied, except for the above mentioned
- The remedies provided herein are the buyers' sole and exclusive remedies.
- INMOTION Controls, Inc. shall not be liable for any direct/indirect, special, incidental or consequential damages.

Important Information

Before You Start

1. Read this manual carefully before operating and installation.
2. Due to the complex nature of equipment, it is necessary to read the entire manual prior to installation.
3. Never allow any unauthorized personnel to dismantle equipment as this may cause damage to the equipment.
4. The equipment has been stringently tested for quality assurance before delivery from factory. However, it must not be used in extremely dangerous situations, or where damage may result.
5. After operation, switch off crane main power as well as receiver unit and remove the rotary key from the transmitter unit.
6. Keep the transmitter in a safe place when not in use to avoid any unintentional operation.
7. The crane should be equipped with a main power relay, limit switches and other required safety devices.
8. Do not use this device during an electrical storm or where there are conditions of high electrical interference/
9. Always check transmitter battery and receiver input power condition before operation.
10. The installation and maintenance service is allowed only when the crane and receiver power are off to avoid electric shock.
11. The contents of the manual may be amended by the manufacturer without notice.
12. The specification and function is subject to change without notice by manufacturer.

Precautions

1. Press EMO (Emergency Off) button and switch off main power of crane and receiver after operation. Then remove transmitter rotary key and keep in a safe place.
2. The following situations may cause a receiver response delay. You should stop operation immediately if these situations occur.
 - (a) If you go beyond the operating range.
 - (b) During severe radio interference.
3. Remove transmitter batteries when not used for a long period of time.
4. To extend product life, please follow the standard operating procedure and maintain system regularly.
5. Check EMO button and other system main functions before operation.
6. Press EMO button during system failure or any abnormal conditions occur.
7. The operator must be familiar with emergency procedures before operating the system.

Emergency Procedures

In case of emergency, please follow the procedure below:

1. Press EMO button and stop operation.
2. Switch the rotary key to “OFF” position and remove it from transmitter unit.
3. Switch off crane main power.
4. Contact an authorized distributor for further assistance.

Specification

General Specification

ID Code.....	Over 1 Million Sets
Channel Space.....	25 KHz
Hamming Distance.....	≥ 4
Structure.....	Enhanced Glass-Fiber
Operating Environment.....	-40°F ~ +185°F
Operating Distance.....	Up to 300 Feet

Transmitter

Power.....	(4) AA Alkaline Batteries
Emission Power.....	<10mW
Dimensions.....	6.42" x 1.93" x 1.77"
Weight.....	0.463 lbs.

Receiver

Power.....	24/48/110/220VAC ($\pm 20\%$)
Dimensions.....	6.57" x 6.06" x 3.46"
Weight.....	4.63 lbs.

Transmitter Overview

Inmotion Series 342 Transmitter Overview

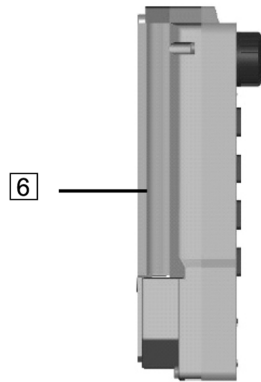
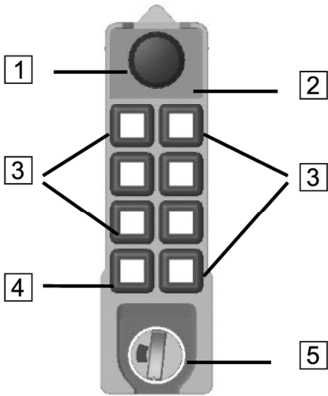

- 1 EMS Button
- 3 Function Button
- 5 Rotary Key

- 2 LED Indicator
- 4 START /Alarm Button
- 6 Battery Cover

Receiver Overview

Inmotion Series 342 Receiver Overview

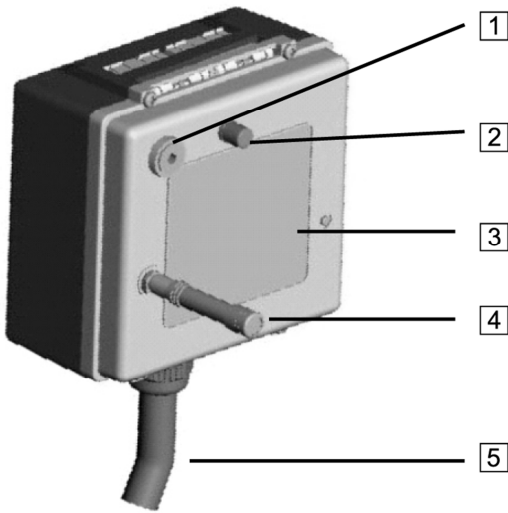

- 1 Alarm (Horn)
- 2 Power-On Indicator
- 3 Receiver Wiring Diagram
- 4 Antenna
- 5 Cable

General Operation

Getting Started

1. Install 4 new AA-size batteries in the battery compartment (make sure batteries are correctly installed according to “Positive” & “Negative”) and close the battery cover firmly.
2. Insert rotary key into transmitter unit and switch to “ON” position.
3. Press START button to power on the system.
Note: Red LED indicator will flash if this procedure is not followed accordingly.
4. Press function button for operation.

Follow the procedure below when finished with operation.

1. Press EMO button.
2. Switch rotary key to “OFF” position.
3. Remove rotary key and keep in a safe place.
4. Remove batteries if not to be used for a long period of time.

Transmitter LED Indicator

Green (Full Power)	Operate as usual.
Yellow (Mid Power)	Unload the article as soon as possible and stop operation until old batteries are replaced with fresh batteries.
Red (Low Power)	An EMS signal will be sent to the receiver automatically to turn off receiver. To avoid interruption during operation, check battery power frequently.

Receiver Voltage Selection

There are two types of power voltages (DC and AC) available for the Series 342.

1) DC Type:

Input Voltage: 12~24 VDC

Relay Contact: 6.7A-36 VDC

2) AC Type:

Three different AC transformers:

48/110/220V, 48/220/380V, 110/220/380V.

Please disconnect the Receiver's power, select the proper voltage, and plug in the connector. See picture below.



Note: Standard Systems are 48/110/220 VAC. If any others are required, please specify when ordering.

FREQUENCY CHART

Ch	Freq. MHz	Ch	Freq. MHz	Ch	Freq. MHz	Ch	Freq. MHz
1	433.050	21	433.550	41	434.050	61	433.550
2	433.075	22	433.575	42	434.075	62	433.575
3	433.100	23	433.600	43	434.100	63	433.600
4	433.125	24	433.625	44	434.125	64	433.625
5	433.150	25	433.650	45	434.150	65	433.650
6	433.175	26	433.675	46	434.175	66	433.675
7	433.200	27	433.700	47	434.200	67	433.700
8	433.225	28	433.725	48	434.225	68	433.725
9	433.250	29	433.750	49	434.250	69	433.750
10	433.275	30	433.775	50	434.275	70	433.775
11	433.300	31	433.800	51	434.300		
12	433.325	32	433.825	52	434.325		
13	433.350	33	433.850	53	434.350		
14	433.375	34	433.875	54	434.375		
15	433.400	35	433.900	55	434.400		
16	433.425	36	433.925	56	434.425		
17	433.450	37	433.950	57	434.450		
18	433.475	38	433.975	58	434.475		
19	433.500	39	434.000	59	434.500		
20	433.525	40	434.025	60	434.525		

Installation Notes

Receiver Wiring Diagram



INMOTION Controls
(888) 501-2220
MODEL: 342 SERIES RX

S/N:

CH.:

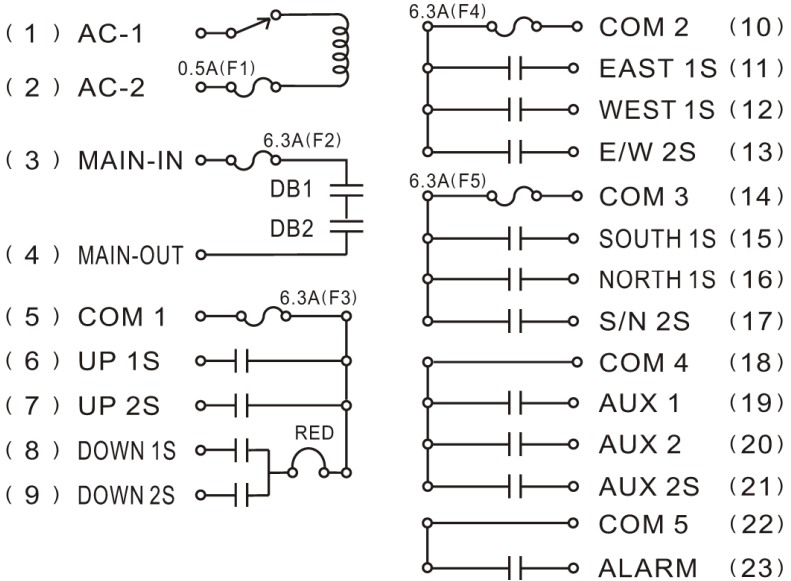

FCC ID: NCT081K

CE 0470 IC:2802A-081K

**Do You Have a
Harsh Environment?
Are Your Operators
Tough on Transmitters?**



**Try Our Neoprene
Rubber Boots**